

1404

Setting standards

Wacker Neuson Compact Excavator 1404





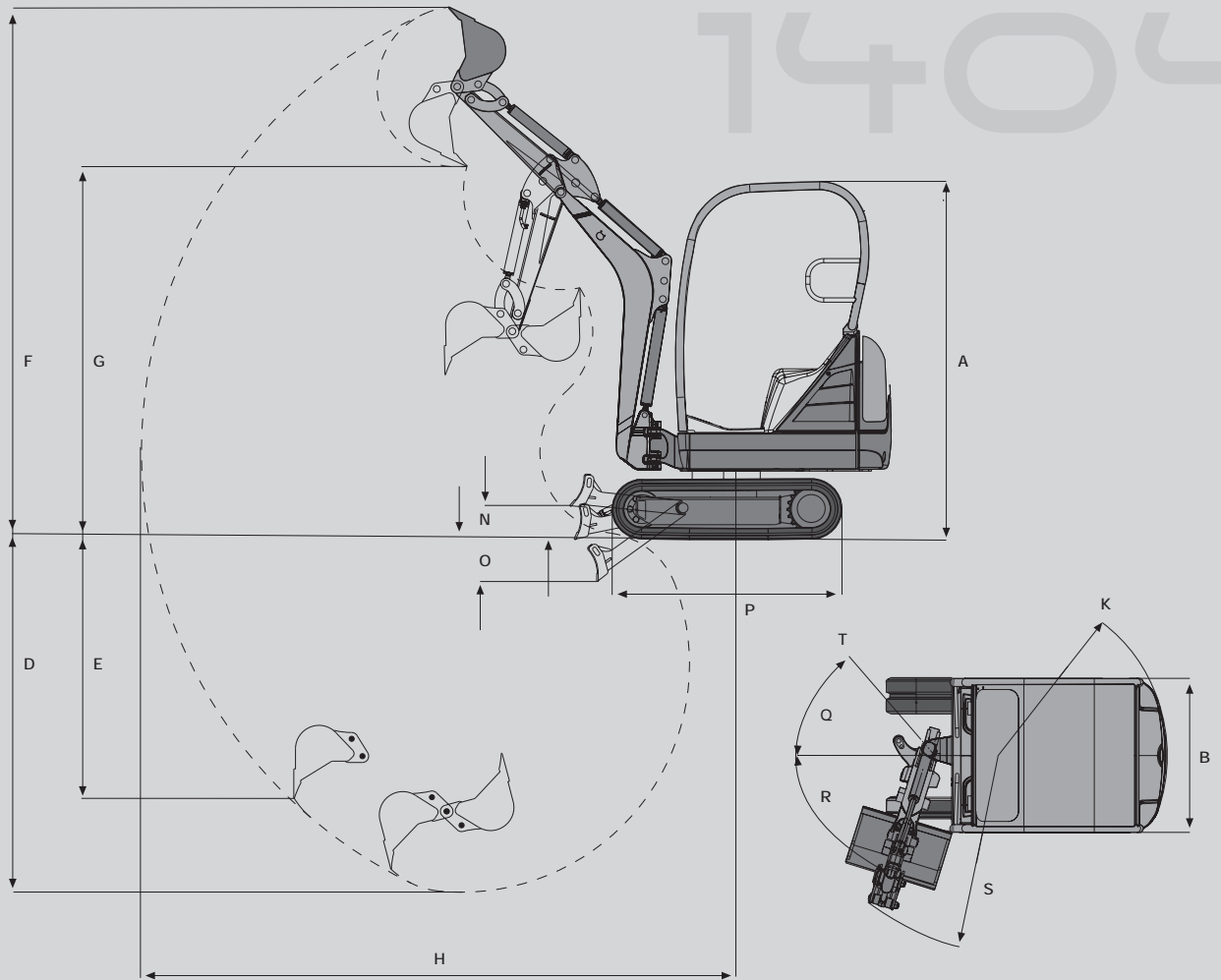



**WACKER
NEUSON**



DIMENSIONS

	1404
A Height	2276 mm
B Width	990 mm
Transport length (boom down)	3645 mm
D Max. digging depth	2240 mm
E Max. vertical digging depth	1640 mm
F Max. digging height	3390 mm
G Max. dumping height	2370 mm
H Max. digging radius	3700 mm
Max. reach on the ground	3650 mm
K Tail slewing radius	1075 mm
L Max. dumping height	2380 mm
Max. boom offset to centre of bucket right side	432 mm
Max. boom offset to centre of bucket left side	287 mm
N Max. lift of dozer blade above ground	211 mm
O Max. digging depth of dozer blade below ground	264 mm
P Track length	1460 mm
Q Max. swing angle of boom system to the right	49 °
R Max. swing angle of boom system to the left	73 °
S Min. boom slewing radius	1490 mm
T Crawler width	230 mm
Max. tear-out force	7.1 kN
Max. bucket digging force	14.2 kN

	OPERATIONAL DATA	1404
	Transport weight with cab / canopy	1450 kg · 1325 kg
	Transport weight with cab / canopy and telescopic undercarriage	1515 kg · 1390 kg
	ENGINE	
	Make/Type	Yanmar 3TNV76
	Model	water-cooled 3-cylinder diesel engine
	Max. engine output	17.9 kW (24.3 PS)
	Performance to ISO	13.2 kW (17.9 PS)
	Engine displacement	1116 cm ³
	Engine speed	2200 min ⁻¹
	Battery	12 V, 45 Ah
	Fuel tank capacity	24 l
	HYDRAULIC SYSTEM	
	Pump	gear pump
	Flow rate	35 l/min
	Operating pressure for working and driving hydraulics	200 bar
	Operating pressure for slewing gear	150 bar
	Hydraulic tank capacity	20 l
	UNDERCARRIAGE AND SLEWING SYSTEM	
	Travel speed	2.5 km/h
	Gradeability	30° / 58 %
	Crawler width	230 mm
	No. of track rollers per side	3
	Ground clearance	180 mm
	Ground pressure	0.26 km/cm ²
	Superstructure slewing speed	9.8 min ⁻¹
	DOZER BLADE	
	Width	980 mm
	Height	232 mm
	Max. lift above ground	211 mm
	Max. lift below ground	264 mm
	NOISE EMISSIONS	
	Noise level (LWA) as per 2000/14/EC	93 dB(A)

	LIFTING POWER TABLE 1404						
	B	A max.		3.0 m		2.0 m	
		along	across	along	across	along	across
		Tele 990 mm / 1300 mm		Tele 990 mm / 1300 mm		Tele 990 mm / 1300 mm	
	1.5 m	395*	205 / 295	400*	210 / 300	430*	375 / 545
	1.0 m	380*	195 / 275	405*	210 / 295	615*	360 / 525
	0.5 m	365*	190 / 270	410*	205 / 290	725*	345 / 505
	0.0 m	350*	190 / 275	385*	200 / 300	715*	335 / 495

A = projection from turnstile centre

B = load fixing height from ground level

*The lifting power is hydraulically restricted.

The data (in kg) equate to the machine without digging attachments and are in compliance with ISO 10567. Overall length with dozer blade supported. Neither 75% of the static lifting load nor 87% of the hydraulic lifting power are exceeded.

STANDARD EQUIPMENT**1404****OPTIONS****1404****GENERAL****230 mm rubber track****Dozer blade****Working light mounted to boom****Tool kit**

incl. grease gun and operator manual

ENGINE

Water-cooled Yanmar diesel engine

CAB**Canopy**

Adjustable driver seat with imitation leather cover and safety belt; canopy complies with FOPS-, TOPS- and ROPS-regulations

HYDRAULICS**Load-Sensing-System****Hydraulic oil cooler****Hydraulic pilot control**

via joystick

Valve control

according to ISO, DIN, SAE, PCSA and EURO

Auxiliary hydraulic connections

for two directions of motion, mounted on bucket arm

CAB**Standard cab**

Glazed safety cab

Cab heating

Top window pane swings back

Bottom window pane lifts out

Windscreen wiper/washing system

1 cab door

Covered cab interior

Cab complies with FOPS-, TOPS- and ROPS-regulations

Radio

Radio set with aerial and speakers

HYDRAULICS**Panolin Bio-Oil****BP-Biohyd SE46****Flat-faced couplers****PAINT****Special paint 1 RAL**

(for yellow parts only)

Special paint 1 no RAL

(for yellow parts only)

Special paint cab RAL

(RAL colours only)

MISCELLANEOUS**Working lights**

front

Working lights

front + back

Anti-theft device**Flashing beacon****Long boom arm**

(+160 mm)

Security 24 (1500 h)

Warranty extension to 24 months or 1500 operation hours

Security 24 (2000 h)

Warranty extension to 24 months or 2000 operation hours

Telescopic undercarriage

Hydraulic telescopic undercarriage from 990 mm to 1300 mm, with dozer blade extensions

PACKS**Mirror pack**

Left-side/right-side mirrors

Wacker Neuson compact equipment
offers power and manoeuvrability
on the spot.
Any time, any place.

We consider it a constant duty to ensure that our promise regarding our products and services is fulfilled: Reliability, Trust, Quality, Reactivity, Flexibility and Innovation.

Compact construction equipment of the Wacker Neuson brand also does the business where others can only stand and watch. Our products prove their worth through quality, power, intelligent hydraulics, compact dimensions, innovative technology, high productivity and reliability.

This gives a form of set-up that only Wacker Neuson – the specialist in compact equipment– is capable of.

You too can take advantage of this bespoke capability. The Wacker Neuson compact class is in a class of its own. With success stamped right through it.



**WACKER
NEUSON**